

	FDCL221-Ex
en	Line adapter (Ex)
de	Linienadapter (Ex)
fr	Adaptateur de ligne (Ex)
es	Adaptador de línea (Ex)
it	Adattatore di linea (Ex)
tr	Hat adaptörü (Ex)

en	Installation
de	Montage
fr	Montage
es	Montaje
it	Montaggio
tr	Kurulum

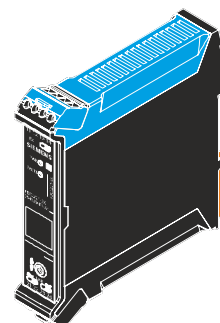

Fig. 1

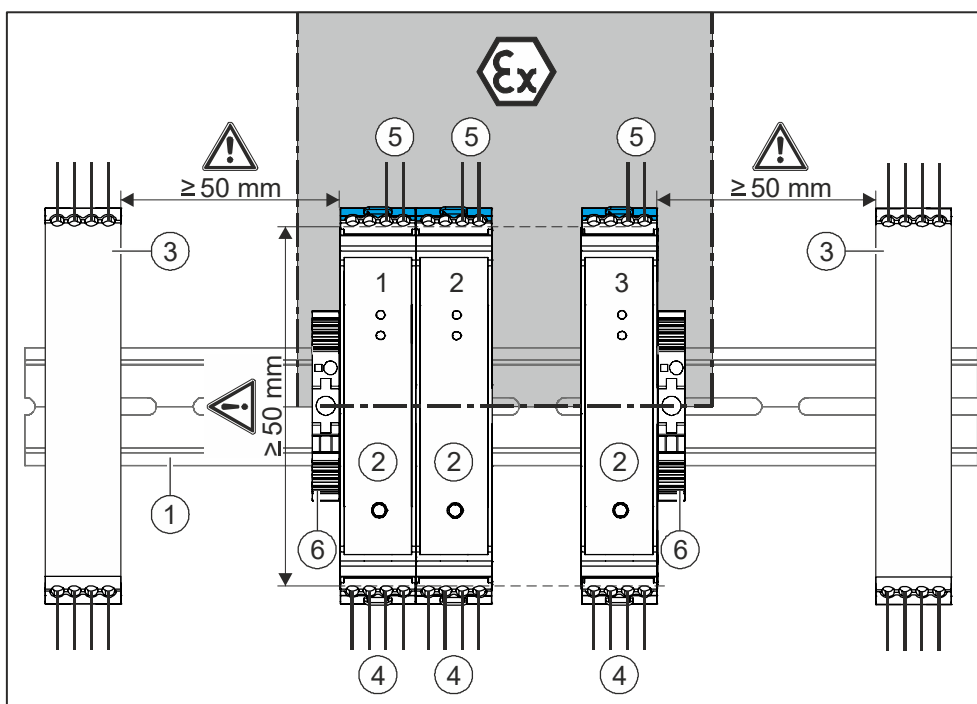

Fig. 2

	en	de	fr	es	it	tr
1	U-rail TS35	Hut-Tragschiene TS35	Rail de support à chapeau TS35	Carril DIN TS35	Top hat rail TS35	TS35 U-ray
2	Line adapter (Ex) FDCL221-Ex	Linienadapter (Ex) FDCL221-Ex	Adaptateur de ligne (Ex) FDCL221-Ex	Adaptador de línea (Ex) FDCL221-Ex	Adattatore di linea (Ex) FDCL221-Ex	FDCL221-Ex hat adaptörü (Ex)
3	Additional devices on the U-rail TS35	Zusätzliche Geräte auf der Hut-Tragschiene TS35	Appareils supplémentaires sur le rail de support à chapeau TS35	Dispositivos adicionales sobre el carril DIN TS35	Apparecchi supplementari sulla top hat rail TS35	TS35 U-ray üzerinde ilave cihazlar

	en	de	fr	es	it	tr
4	Lines for detector line	Leitungen Melderlinie	Câbles de ligne de détection	Cables línea de detectores	Cavi della linea di rivelatori	Dedektör hattı için hatlar
5	Lines in the intrinsically safe area	Leitungen in den eigensicheren Bereich	Câbles en zone de sécurité intrinsèque	Cables en la zona intrínsecamente segura	Cavi nell'area a sicurezza intrinseca	Kendinden güvenli alandaki hatlar
6	End brackets	Endwinkel	Équerres d'extrémité	Escuadras finales	Squadrette terminali	Uç braketleri

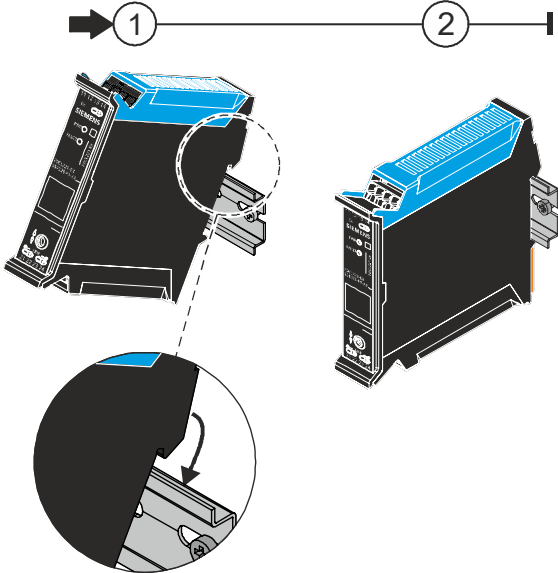

Fig. 3

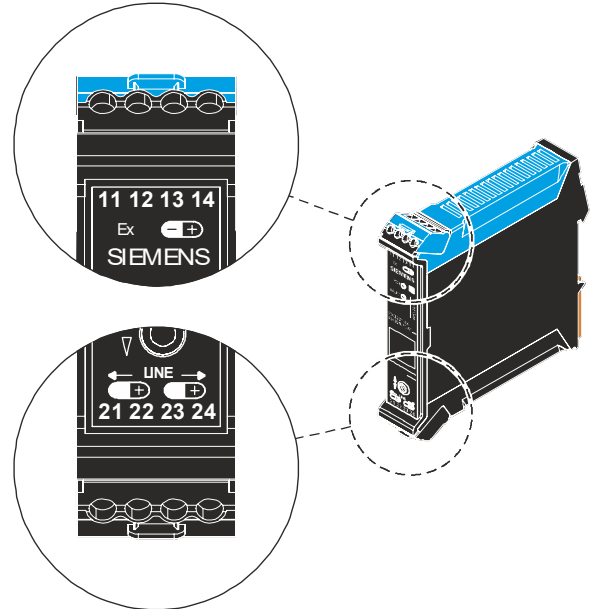

Fig. 4

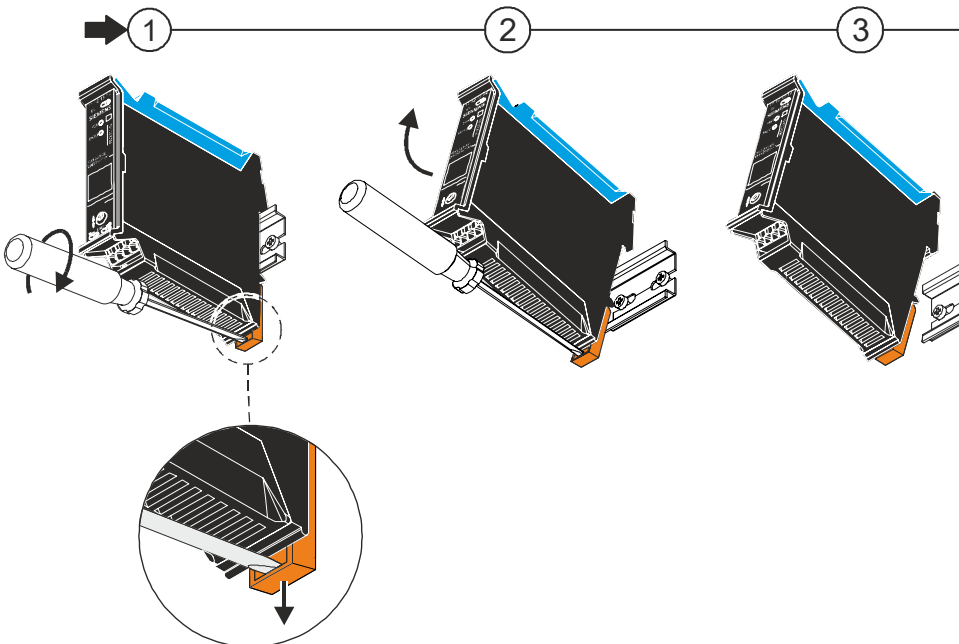

Fig. 5



WARNING
Risk of explosion
Install the line adapter (Ex) FDCL221-Ex outside the area at risk of explosion!

Description

The line adapter (Ex) FDCL221-Ex (Fig. 1) is used for electrical isolation and for limiting the electrical energy between non-intrinsically safe and intrinsically safe circuits. The electrical power in the intrinsically safe circuit is limited to a level that is low enough to prevent electrical sparks from igniting a gas mixture or dust. The intrinsically safe area of the line adapter (Ex) has bright blue marking. The line adapter (Ex) can be installed in a fire control panel FC20xx or FC72x or in a housing FDCH222 (accessories). It is installed on a U-rail TS35 in both cases.

Intended use

The line adapter (Ex) FDCL221-Ex may only be used as follows:

- On an FDnet/C-NET detector line in a fire detection installation FS20/FS720.
- For separating intrinsically safe circuits from non-intrinsically safe circuits in a fire detection installation FS20/FS720, using ignition protection category 'Intrinsic safety Ex i'.
- The line adapter (Ex) FDCL221-Ex must be installed outside the area at risk of explosion.

Creepage distance (Fig. 2)

In accordance with EN 60079-11, a minimum distance of 50 mm must be ensured between intrinsically safe and non-intrinsically safe connections. Observe this minimum distance when installing the line adapter (Ex).



Local regulations may prescribe a larger minimum distance. Check the regulations that apply to the installation location concerned.

Installation on a U-rail TS35 (Fig. 3)

1. Turn the line adapter (Ex) so that it is in the installation position (bright blue side facing up).
2. Hook the line adapter (Ex) onto the U-rail TS35 using the installation protrusion, as shown in the figure.
3. Push the line adapter (Ex) down until you hear the snap fitting on the rear of the line adapter (Ex) latch into place.

Removal from a U-rail TS35 (Fig. 5)

1. Insert the blade of a flat-blade screwdriver (size 2) in the opening in the snap fitting.
 2. Turn the handle of the flat-blade screwdriver around 90° and hold it in this position.
- ➔ The snap fitting is unlocked.

3. Pivot the line adapter (Ex) up and detach the U-rail TS35 from the line adapter (Ex).
- ➔ The line adapter (Ex) is removed from the U-rail TS35.

Connecting the line adapter (Ex) (Fig. 4)

Bright blue terminal strip (area at risk of explosion)

Terminal number	Connection	Detector line
11	Not used	FDnet-Ex/ C-NET-Ex
12	Not used	
13	–	
14	+	

Black terminal strip (area not at risk of explosion)

Terminal number	Connection	Detector line
21	–	FDnet/C-NET
22	+	
23	–	
24	+	



Observe the positive and negative poles. Only connect one wire per terminal. This is the only way to ensure a fault-free connection throughout the entire service life of the device.

1. Install the lines for the intrinsically safe circuit in the bright blue terminal strip. Bare length of cables: 8...10 mm.
 2. **NOTICE! The terminal strips feature coded connectors in order to prevent the lines from getting mixed up! Do not push the terminal strip onto the line adapter (Ex) forcefully!**
 3. Push the bright blue terminal strip onto the line adapter (Ex).
 4. Repeat steps 1...3 as appropriate for the black terminal strip.
- ➔ The lines are connected to the line adapter (Ex).



You will find more information in documents A6V10333771 and A6V10324618.



If you are permanently decommissioning the equipment, observe the national regulations governing unused cables in areas at risk of explosion.

Installation in housing FDCH222 (accessories)

Up to three line adapters (Ex) FDCL221-Ex can be installed in the housing FDCH222.



You will find more information in documents A6V10333771 and A6V10397617.



WARNUNG
Explosionsgefahr
Montieren Sie den Linienadapter (Ex)
FDCL221-Ex außerhalb des explosions-
gefährdeten Bereichs!

Beschreibung

Der Linienadapter (Ex) FDCL221-Ex (Fig. 1) dient zur galvanischen Trennung und zur Begrenzung der elektrischen Energie zwischen nicht eigensicheren Stromkreisen und eigensicheren Stromkreisen. Die elektrische Leistung im eigensicheren Stromkreis wird so weit begrenzt, dass elektrische Funken ein Gasgemisch oder Staub nicht entzünden können. Der eigensichere Bereich des Linienadapters (Ex) ist hellblau gekennzeichnet.

Der Linienadapter (Ex) kann in einer Brandmeldezentrale FC20xx oder FC72x oder in einem Gehäuse FDCH222 (Zubehör) montiert werden. Die Montage erfolgt in beiden Fällen auf einer Hut-Tragschiene TS35.

Bestimmungsgemäße Verwendung

Der Linienadapter (Ex) FDCL221-Ex darf nur wie folgt verwendet werden:

- Einsatz auf einer FDnet-/C-NET-Melderlinie in einer Brandmeldeanlage FS20/FS720.
- Zum Trennen von eigensicheren Stromkreisen von nicht eigensicheren Stromkreisen in einer Brandmeldeanlage FS20/FS720 unter Verwendung der Zündschutzart 'Eigensicherheit Ex i'.
- Die Montage des Linienadapters (Ex) FDCL221-Ex muss außerhalb des explosionsgefährdeten Bereichs erfolgen.

Kriechstreckenabstand (Fig. 2)

Nach EN 60079-11 muss zwischen eigensicheren und nicht eigensicheren Anschlüssen ein Mindestabstand von 50 mm gewährleistet sein. Beachten Sie bei der Montage des Linienadapters (Ex) diesen Mindestabstand!



Durch lokale Vorschriften kann ein größerer Mindestabstand vorgeschrieben sein! Überprüfen Sie die für den Montageort geltenden Vorschriften.

Montage auf Hut-Tragschiene TS35 (Fig. 3)

1. Drehen Sie den Linienadapter (Ex) in Montageposition (hellblaue Seite oben).
2. Hängen Sie den Linienadapter (Ex) wie in der Grafik dargestellt mit der Montagenase in die Hut-Tragschiene TS35 ein.
3. Drücken Sie den Linienadapter (Ex) nach unten, bis der Schnappverschluss auf der Rückseite des Linienadapters (Ex) hörbar einrastet.

Demontage von einer Hut-Tragschiene TS35 (Fig. 5)

1. Stechen Sie mit der Klinge eines Schlitz-Schraubendrehers (Größe 2) in die hervorstehende Öffnung des Schnappverschlusses.

2. Drehen Sie den Griff des Schlitz-Schraubendrehers um ca. 90° und halten Sie den Griff in dieser Position.
 → Der Schnappverschluss wird entriegelt.
3. Klappen Sie den Linienadapter (Ex) nach oben und nehmen Sie die Hut-Tragschiene TS35 vom Linienadapter (Ex) ab.
 → Der Linienadapter (Ex) ist von der Hut-Tragschiene TS35 demontiert.

Anschließen des Linienadapters (Ex) (Fig. 4)

Hellblaue Klemmenleiste (explosionsgefährdeter Bereich)

Klemmennummer	Anschluss	Melderlinie
11	Nicht belegt	FDnet-Ex/ C-NET-Ex
12	Nicht belegt	
13	–	
14	+	

Schwarze Klemmenleiste (nicht explosionsgefährdeter Bereich)

Klemmennummer	Anschluss	Melderlinie
21	–	FDnet/C-NET
22	+	
23	–	
24	+	



Beachten Sie die Plus- und Minus-Anschlüsse. Schließen Sie pro Klemme nur einen Draht an. Nur so kann ein störungsfreier Anschluss über die gesamte Lebensdauer des Gerätes gewährleistet werden.

1. Installieren Sie die Leitungen des eigensicheren Stromkreises in der hellblauen Klemmenleiste. Abisolierlänge der Kabel: 8...10 mm.
2. **HINWEIS! Die Klemmenleisten sind mit kodierten Steckern versehen, um Verwechslungen auszuschließen! Schieben Sie die Klemmenleiste nicht mit Gewalt auf den Linienadapter (Ex)!**
3. Schieben Sie die hellblaue Klemmenleiste auf den Linienadapter (Ex).
4. Wiederholen Sie die Schritte 1...3 sinngemäß für die schwarze Klemmenleiste.
 → Die Leitungen sind am Linienadapter (Ex) angeschlossen.



Weitere Informationen finden Sie in den Dokumenten A6V10333771 und A6V10324618.



Beachten Sie bei dauerhafter Außerbetriebsetzung die nationalen Vorschriften für ungenutzte Kabel im explosionsgefährdeten Bereich.

Montage in Gehäuse FDCH222 (Zubehör)

In das Gehäuse FDCH222 können bis zu drei Linienadapter (Ex) FDCL221-Ex montiert werden.



Weitere Informationen finden Sie in den Dokumenten A6V10333771 und A6V10397617.



AVERTISSEMENT
Risque d'explosion
Montez l'adaptateur de ligne (Ex) FDCL221-Ex à l'extérieur de la zone explosive !

Description

L'adaptateur de ligne (Ex) FDCL221-Ex (fig. 1) assure l'isolation galvanique et la limitation de l'énergie électrique entre les circuits électriques sans sécurité intrinsèque et ceux avec sécurité intrinsèque. La puissance électrique dans le circuit de sécurité intrinsèque est limitée de manière à ce que des étincelles électriques ne puissent pas enflammer un mélange gazeux ou la poussière. La zone de sécurité intrinsèque de l'adaptateur de ligne (Ex) est de couleur bleu claire.

L'adaptateur de ligne (Ex) peut être monté dans un équipement de contrôle et signalisation FC20xx ou FC72x ou dans un boîtier IBDCL221 (accessoire). Dans les deux cas, le montage s'effectue sur un rail de support à chapeau TS35.

Utilisation conforme

L'adaptateur de ligne (Ex) FDCL221-Ex ne doit être utilisé que comme suit :

- Installation sur une ligne de détection FDnet-/C-NET dans une installation de détection d'incendie FS20/FS720.
- Pour la séparation de circuits de sécurité intrinsèque de circuits sans sécurité intrinsèque dans une installation de détection d'incendie FS20/FD720 dans le cadre de l'application de la protection antidéflagrante 'Sécurité intrinsèque Ex i'.
- Le montage de l'adaptateur de ligne (Ex) FDCL221-Ex doit être effectué en dehors de la zone explosive.

Distance de ligne de fuite (fig. 2)

Selon EN 60079-11, une distance minimale de 50 mm doit être garantie entre des connexions de sécurité intrinsèque et des connexions sans sécurité intrinsèque. Respectez cette distance lors du montage de l'adaptateur de ligne (Ex) !



Des prescriptions locales peuvent spécifier une distance minimal supérieure ! Reportez-vous aux prescriptions en vigueur pour le lieu du montage.

Montage sur rail de support à chapeau TS35 (fig. 3)

1. Tournez l'adaptateur de ligne (Ex) en position de montage (côté bleu clair vers le haut).
2. Accrochez l'adaptateur de ligne (Ex) dans l'ergot de montage sur le rail de support à chapeau TS35 comme indiqué sur le schéma.
3. Appuyez l'adaptateur de ligne (Ex) vers le bas jusqu'à ce que le fermoir à cliquet sur la partie arrière de l'adaptateur de ligne (Ex) s'encliquette de façon audible.

Démontage d'un rail de support à chapeau TS35 (fig. 5)

1. Insérez la pointe d'un tournevis plat (taille 2) dans l'ouverture qui dépasse dans le fermoir à cliquet.

2. Tournez la poignée du tournevis plat sur environ 90° et maintenez la poignée dans cette position.

→ Le fermoir à cliquet est débloqué.

3. Basculez l'adaptateur de ligne (Ex) vers le haut et séparez le rail de support à chapeau TS35 de l'adaptateur de ligne (Ex).

→ L'adaptateur de ligne (Ex) est démonté du rail de support à chapeau TS35.

Raccordement d'un adaptateur de ligne (Ex) (fig. 4)

Barrette à bornes bleu claire (zone explosive)

Numéro de borne	Raccordement	Ligne de détection
11	Non affecté	FDnet-Ex/ C-NET-Ex
12	Non affecté	
13	-	
14	+	

Barrette à bornes noire (zone non explosive)

Numéro de borne	Raccordement	Ligne de détection
21	-	FDnet/C-NET
22	+	
23	-	
24	+	



Attention aux bornes plus et moins. Raccordez un seul fil par borne. C'est le seul moyen de garantir une connexion sans problème pendant toute la durée de vie de l'appareil.

1. Posez les câbles du circuit de sécurité intrinsèque dans la barrette à bornes bleu claire. Longueur brute des câbles : 8...10 mm.
2. **AVIS ! Les barrettes à bornes sont munies de fiches codées afin d'empêcher toute confusion ! N'insérez pas la barrette à bornes en force sur l'adaptateur de ligne (Ex) !**

3. Insérez la barrette à bornes bleu claire sur l'adaptateur de ligne (Ex).

4. Répétez les étapes 1 à 4 de la même façon pour la barrette à bornes noire.

→ Les câbles sont raccordés sur l'adaptateur de ligne (Ex).



Pour de plus amples informations, se référer aux documents A6V10333771 et A6V10324618.



En cas de mise hors service prolongée, respectez les prescriptions nationales concernant les câbles non utilisés en zone explosive.

Montage dans un boîtier FDCH222 (accessoire)

Dans le boîtier FDCH222, il est possible de monter jusqu'à trois adaptateurs de ligne (Ex) FDCL221-Ex.



Pour de plus amples informations, se référer aux documents A6V10333771 et A6V10397617.



ADVERTENCIA

Riesgo de explosión

Monte el adaptador de línea (Ex) FDCL221-Ex fuera de la zona con riesgo de explosión

Descripción

El adaptador de línea (Ex) FDCL221-Ex (Fig. 1) sirve para la separación galvánica y la limitación de la energía eléctrica entre circuitos eléctricos no intrínsecamente seguros y circuitos eléctricos intrínsecamente seguros. El rendimiento eléctrico en el circuito eléctrico intrínsecamente seguro se limita de manera que chispas eléctricas no puedan encender una mezcla de gas o polvo. La zona intrínsecamente segura del adaptador de líneas (Ex) está indicado con azul claro.

El adaptador de línea (Ex) puede montarse en una unidad de control de detección de incendios FC20xx o FC72x o en una carcasa FDCH222 (accesorios). En ambos casos, el montaje se realizará sobre un carril DIN TS35.

Uso previsto

El adaptador de líneas (Ex) FDCL221-Ex debe emplearse únicamente como se indica a continuación:

- Empleo en una línea de detectores FDnet/C-NET en una instalación de detección de incendios FS20/FS720
- Para separar circuitos eléctricos intrínsecamente seguros de circuitos eléctricos no intrínsecamente seguros en una instalación de detección de incendios FS20/FS720 con la utilización del grado de protección contra explosiones 'Seguridad intrínseca Ex i'
- El montaje del adaptador de línea (Ex) FDCL221-Ex debe realizarse fuera de la zona con peligro de explosión.

Distancia de línea de fuga (fig. 2)

Según EN 60079-11 entre las conexiones intrínsecamente seguras y las no intrínsecamente seguras debe haber una distancia mínima de 50 mm. Para el montaje del adaptador de línea (ex) tenga en cuenta esta distancia mínima.



Las normas locales pueden prescribir una distancia mínima mayor. Compruebe las normas vigentes para el lugar de montaje.

Montaje en el carril DIN TS35 (fig. 3)

1. Gire el adaptador de línea (Ex) en el posición de montaje (parte azul clara superior).
2. Cuelgue el adaptador de línea (ex) tal y como se representa en el gráfico con el pico de montaje en el carril DIN TS35.
3. Presione el adaptador de línea (Ex) hacia abajo, hasta que el mosquetón encaje de manera audible en la parte posterior del adaptador de línea (Ex).

Desmontaje de un carril DIN TS35 (fig. 5)

1. Introduzca la hoja de un destornillador de ranura longitudinal (tamaño 2) en el orificio que sobresale del mosquetón.

2. Gire el mango del destornillador de ranura longitudinal aprox. 90° y mantenga el mango en esa posición.
→ Se desbloquea el mosquetón.
3. Desdoble el adaptador de línea (Ex) hacia arriba y retire el carril DIN TS35 del adaptador de línea (Ex).
→ Se ha desmontado adaptador de línea (Ex) del carril DIN TS35.

Conexión del adaptador de línea (Ex) (fig. 4)

Regleta de terminal azul claro (zona con riesgo de explosión)

Número de terminales	Conexión	Línea de detectores
11	No asignado	FDnet-Ex/ C-NET-Ex
12	No asignado	
13	-	
14	+	

Regleta de terminal negra (zona sin riesgo de explosión)

Número de terminales	Conexión	Línea de detectores
21	-	FDnet/C-NET
22	+	
23	-	
24	+	



Observe los polos positivos y negativos. Conecte únicamente un hilo por terminal. Sólo así podrá garantizarse una conexión sin fallos durante la vida útil completa del dispositivo.

1. Instale los cables del circuito eléctrico intrínsecamente seguro en la regleta de terminales azul claro. Longitud sin aislar del cable: 8...10 mm.
2. **AVISO. Las regletas de terminales están provistas de enchufes codificados para excluir la posibilidad de intercambios. No empuje la regleta de terminales con violencia en el adaptador de línea (Ex)**
3. Empuje la regleta de terminales de color azul claro en el adaptador de línea (Ex).
4. Repita los pasos 1...3 conforme al sentido para la regleta de terminales negra.
→ Los cables están conectados al adaptador de línea (Ex).



Para más información consulte el documento A6V10333771 y A6V10324618.



En caso de puesta fuera de servicio prolongada tenga en cuenta las normas nacionales para cables no utilizados en zonas con riesgo de explosión.

Montaje en carcasa FDCH222 (accesorios)

En la carcasa FDCH222 pueden montarse hasta tres adaptadores de línea (Ex) FDCL221-Ex .



Para más información al respecto, consulte los documentos A6V10333771 y A6V10397617.



AVVERTENZA
Pericolo di esplosione
Montare l'adattatore di linea (Ex) FDCL221-Ex
all'esterno dell'area a rischio di esplosione!

Descrizione

L'adattatore di linea (Ex) FDCL221-Ex (Fig. 1) serve per l'isolamento galvanico e la limitazione della corrente tra circuiti elettrici a e senza sicurezza intrinseca. La potenza elettrica del circuito a sicurezza intrinseca viene limitata in modo che le scintille elettriche non possano accendere una miscela di gas o la polvere. L'area a sicurezza intrinseca dell'adattatore di linea (Ex) è contrassegnata in azzurro.

L'adattatore di linea (Ex) può essere montato in una centrale rivelazione incendio FC20xx o FC72x, oppure in un contenitore FDCH222 (accessorio). Il montaggio si esegue in entrambi i casi su una top hat rail TS35.

Utilizzo conforme alle disposizioni

L'adattatore di linea (Ex) FDCL221-Ex può essere utilizzato soltanto come segue:

- Impiego su una linea di rivelatori FDnet/C-NET in un impianto rivelazione incendio FS20/FS720.
- Per l'isolamento tra circuiti elettrici a e senza sicurezza intrinseca in un impianto rivelazione incendio FS20/FS720, utilizzando il tipo di protezione contro l'accensione 'Sicurezza intrinseca Ex i'
- Il montaggio dell'adattatore di linea (Ex) FDCL221-Ex deve avvenire all'esterno dell'area a rischio di esplosione.

Distanza d'isolamento superficiale (fig. 2)

Secondo la norma EN 60079-11, si deve garantire una distanza minima di 50 mm tra le connessioni a e senza sicurezza intrinseca. Attenersi a questa distanza minima per il montaggio dell'adattatore di linea (Ex)!

i Le normative locali possono anche prescrivere una distanza minima maggiore! Verificare le prescrizioni vigenti per il luogo di montaggio.

Montaggio sulla top hat rail TS35 (fig. 3)

1. Ruotare l'adattatore di linea (Ex) nella posizione di montaggio (lato azzurro in alto).
2. Agganciare il dente di montaggio dell'adattatore di linea (Ex) nella top hat rail TS35 come illustrato nella figura.
3. Spingere l'adattatore di linea (Ex) verso il basso, finché la chiusura a scatto posta sul suo retro non si blocca in posizione con un clic.

Smontaggio da una top hat rail TS35 (fig. 5)

1. Infilare la lama di un cacciavite piatto (misura 2) nell'apertura sporgente della chiusura a scatto.

2. Ruotare l'impugnatura del cacciavite piatto di ca. 90° e mantenerla in questa posizione.

→ La chiusura a scatto viene sbloccata.

3. Ribaltare l'adattatore di linea (Ex) verso l'alto e rimuovere la top hat rail TS35 dal dispositivo.

→ L'adattatore di linea (Ex) è smontato dalla top hat rail TS35.

Collegamento dell'adattatore di linea (Ex) (fig. 4)

Morsettiera azzurra
(area a rischio di esplosione)

Numero morsetto	Connessione	Linea di rivelatori
11	Non occupato	FDnet-Ex/ C-NET-Ex
12	Non occupato	
13	-	
14	+	

Morsettiera nera
(area non a rischio di esplosione)

Numero morsetto	Connessione	Linea di rivelatori
21	-	FDnet/C-NET
22	+	
23	-	
24	+	

i Fare attenzione ai poli positivi e negativi. Collegare un solo filo per morsetto. Solo così può essere garantito un collegamento privo di disturbi durante l'intero ciclo di vita dell'apparecchio.

1. Installare le linee del circuito elettrico a sicurezza intrinseca nella morsettiera azzurra. Lunghezza di spelatura dei cavi: 8...10 mm.
 2. **NOTA! Le morsettiere sono dotate di connettori codificati per escludere errori di scambio! Applicare la morsettiera facendola scorrere delicatamente sull'adattatore di linea (Ex)!**
 3. Applicare la morsettiera azzurra facendola scorrere sull'adattatore di linea (Ex).
 4. Ripetere i punti 1...3 in modo analogo per la morsettiera nera.
- Le linee sono collegate all'adattatore di linea (Ex).

i Per maggiori informazioni, si rimanda ai documenti A6V10333771 e A6V10324618.

i In caso di messa fuori servizio prolungata, attenersi alle normative nazionali per i cavi inutilizzati nell'area a rischio di esplosione.

Montaggio nel contenitore FDCH222 (accessorio)

Nel contenitore FDCH222 si possono montare al massimo tre adattatori di linea (Ex) FDCL221-Ex.

i Per maggiori informazioni in merito, si rimanda ai documenti A6V10333771 e A6V10397617.

**UYARI****Patlama riski****FDCL221-Ex hat adaptörünü (Ex) patlama riski bulunan alanın dışına kurun!****Açıklama**

FDCL221-Ex hat adaptörü (Ex) (Şekil 1), elektrik yalıtımı için ve kendinden güvenli olmayan ve kendinden güvenli devreler arasındaki elektrik enerjisini sınırlamak için kullanılır. Kendinden güvenli devredeki elektrik gücü, elektrik kıvılcıklarının bir gaz karışımını veya tozu tutuşturmasını önlemeye yetecek kadar düşük bir düzeyde sınırlandırılır. Hat adaptörünün (Ex) kendinden güvenli alanı parlak mavi işarete sahiptir.

Hat adaptörü (Ex), bir FC20xx veya FC72x yangın kontrol paneline veya bir FDCH222 muhafazaya (aksesuarlar) kurulabilir. Her iki durumda da bir TS35 U-ray üzerine kurulur.

Kullanım amacı

FDCL221-Ex hat adaptörü (Ex) sadece aşağıdaki gibi kullanılabilir:

- Bir FS20/FS720 yangın algılama teçhizatında bir FDnet/C-NET dedektör hattında.
- 'Kendinden güvenli Ex i' tutuşma koruma kategorisini kullanarak bir FS20/FS720 yangın algılama teçhizatında kendinden güvenli devreleri kendinden güvenli olmayan devrelerden ayırmak için.
- FDCL221-Ex hat adaptörü (Ex) patlama riski bulunan alanın dışına kurulmalıdır.

Kaçak mesafesi (Şekil 2)

EN 60079-11 uyarınca, kendinden güvenli ve kendinden güvenli olmayan bağlantılar arasında minimum 50 mm'lik bir mesafe sağlanmalıdır. Hat adaptörünü (Ex) kurarken bu minimum mesafeye uyun.



Yerel yönetmelikler daha büyük bir minimum mesafe gerektirebilir. İlgili kurulum yerinde geçerli yönetmelikleri kontrol edin.

Bir TS35 U-ray üzerine kurulum (Şekil 3)

1. Hat adaptörünü (Ex) kurulum yerinde olacak (parlak mavi taraf yukarı bakacak) şekilde çevirin.
2. Şekilde gösterildiği gibi kurulum çıkıntısını kullanarak hat adaptörünü (Ex) TS35 U-ray üzerine asın.
3. Hat adaptörünün (Ex) arkasında mandalın yerine oturduğunu duyana kadar hat adaptörünü (Ex) aşağı bastırın.

Bir TS35 U-ray'dan çıkarma (Şekil 5)

1. Düz uçlu tornavidanın (2 numara) ucunu kavrama kilidindeki açıklığa sokun.
 2. Düz uçlu tornavidanın sapını yaklaşık 90° çevirin ve bu konumda tutun.
- Kavrama kilidi açılır.

3. Hat adaptörünü (Ex) yukarı döndürün ve TS35 U-ray hat adaptöründen (Ex) sökün.

→ Hat adaptörü (Ex) TS35 U-raydan çıkarılır. Hat adaptörünü (Ex) bağlama (Şekil 4)

Parlak mavi terminal şeridi
(patlama riskli alan)

Terminal numarası	Bağlantı	Dedektör hattı
11	Kullanılmıyor	FDnet-Ex/ C-NET-Ex
12	Kullanılmıyor	
13	-	
14	+	

Siyah terminal şeridi

(patlama riski olmayan alan)

Terminal numarası	Bağlantı	Dedektör hattı
21	-	FDnet/C-NET
22	+	
23	-	
24	+	



Pozitif ve negatif kutuplara dikkat edin.

Terminal başına yalnızca bir kablo bağlayın. Bu, cihazın tüm kullanım ömrü boyunca hatasız bir bağlantı sağlamanın tek yoludur.

1. Hatları parlak mavi terminal şeridindeki kendinden güvenli devreye kurun. Kabloların yalın uzunluğu: 8...10 mm.
 2. NOT! Terminal şeritleri, hatların karışmasını önlemek amacıyla kodlu konnektörler içerir! Terminal şeridini hat adaptörüne (Ex) zorlayarak bastırmayın!
 3. Parlak mavi terminal şeridini hat adaptörü (Ex) üzerine bastırın.
 4. Siyah terminal şeridi için 1 ila 3. adımları uygun şekilde tekrar edin.
- Hatlar, hat adaptörüne (Ex) bağlanır.



A6V10333771 ve A6V10324618 numaralı belgelerde daha fazla bilgi bulabilirsiniz.



Ekipmanı kalıcı olarak devre dışı bırakıyorsanız patlama riski bulunan alanlarda kullanılmayan kablolarla ilgili ulusal yönetmeliklere uyun.

FDCH222 muhafazasına kurulum (aksesuarlar)
FDCH222 muhafazasına üç adede kadar FDCL221-Ex hat adaptörü (Ex) kurulabilir.

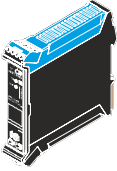

A6V10333771 ve A6V10397617 numaralı belgelerde daha fazla bilgi bulabilirsiniz.

FDCL221-Ex	S54329-F4-A1			en Line adapter (Ex) de Linienadapter (Ex) fr Adaptateur de ligne (Ex) es Adaptador de línea (Ex) it Adattatore di linea (Ex) tr Hat adaptörü (Ex)
------------	--------------	---	--	---

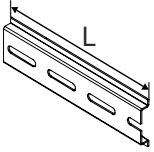

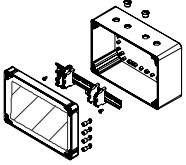

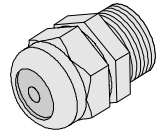

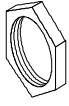
L=122 mm	BPZ:5644780001			en U-rail TS35 de Hut-Tragschiene TS35 fr Rail de support à chapeau TS35 es Carril DIN TS35 it Top hat rail TS35 tr TS35 U-ray
L=288 mm	BPZ:5644230001			

FDCH222	S54329-F10-A1			en Installation housing de Installationsgehäuse fr Boîtier d'installation es Carcasa de instalación it Contenitore di installazione tr Kurulum muhafazası
---------	---------------	---	--	--

---	A5Q00004478			en Metal cable gland M20 x 1.5 de Metall-Kabelverschraubung M20 x 1,5 fr Presse-étoupe métallique M20 x 1,5 es Prensaestopas metálico para cable M20 x 1,5 it Pressacavo metallico M20 x 1,5 tr Metal kablo rakoru M20 x 1.5
-----	-------------	--	--	---

---	A5Q00004479			en Counter nut M20 x 1.5 de Gegenmutter M20 x 1,5 fr Contre-écrou M20 x 1,5 es Contratuerca M20 x 1,5 it Controdado M20 x 1,5 tr Kontra somun M20 x 1.5
-----	-------------	---	--	--

IECEX:	[Ex ia Ga] IIC, Ta = -25...60 °C		
	[Ex ia Da] IIIC, Ta = -25...60 °C		
2014/34/EU: (ATEX-directive)	II (1) G [Ex ia Ga] IIC, Ta = -25...60 °C		
	II (1) D [Ex ia Da] IIIC, Ta = -25...60 °C		
Technical data:	U ₀	28 V	
	I ₀	92 mA	
	P ₀	644 mW	
	L ₀	2.9 mH	
	C ₀	82 nF	
	U _m	253 V	
	Operating current, quiescent (without secondary load)		2.5 mA
	Operating current, max. load (including max. secondary load with FDnet/C-Net MK 50)		18 mA

 A6V10333771	 siemens.com/bt/contact 	  siemens.com/bt/download	 FDCL221-Ex
--	--	--	---

Issued by
Siemens Switzerland Ltd
Smart Infrastructure
Global Headquarters
Theilerstrasse 1a
CH-6300 Zug
Tel. +41 58 – 724 24 24
www.siemens.com/buildingtechnologies

© 2012 Siemens Switzerland Ltd
Technical specifications and availability subject to change without notice.